

WELLCOMP TECHNOLOGY CO., LTD

APPROVAL SHEET

Model Name	Long Terminal Metal Strip Current Sensing Resistor
Part Number	WMCSL Series
Customer Name	
Customer P/N	
Issued Date	

Customer		Maker		
Approved	Checked	Inspector	Checked	Prepared



深圳市元寶科技有限公司
SHENZHEN YUANBAO TECHNOLOGY CO.,LTD
深圳市福田区彩田路彩福大廈聚福閣 25F
25/F,JUFU Block,CAIFU Building Caitian
Road,Futian,Shenzhen
Tel: +86-755-88309095
Fax:+86-755-88309095-807

Features

- ◆ Chip size from: 0508~0612
- ◆ Resistance value from :5~30mΩ
- ◆ Lead free, RoHs compliant for global plications and halogen free

Application

- ◆ Switching Power Supply
- ◆ Voltage Regulation Module
- ◆ DC-DC Converter, Adaptor, Battery Pack, Charger
- ◆ Pad & Cell Phone
- ◆ Power management Applications

Part Numbering System

WMCSL 0508 R005 F S I A
 (1) (2) (3) (4) (5) (6) (7)

- (1) Series Code
- (2) Size (EIA): Length x Width
- (3) Resistance: R002=2mΩ, R010=10mΩ
- (4) Tolerance: F=+/-1%, G=+/-2%, J=+/-5%
- (5) Power Rating: S=1/2W, C=1W, D=1.5W, E=2W
- (6) Packaging: T- Embossed paper tape, 7" reel
 E-Embossed plastic tape, 7" reel
- (7) Factory Code, A=TWN Factory

Dimension

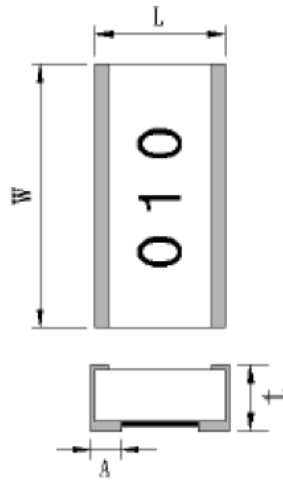

Type (inch size)	Dimensions(mm)			
	L	W	t	A
WMCSL0508	1.30±0.20	2.00±0.20	0.60±0.20	0.30±0.20
WMCSL0612	1.60±0.20	3.20±0.20	0.60±0.20	0.30±0.20

Electrical Specification

Item	Power Rating	Resistance Range(mΩ)	Operation Temp. Range	TCR (PPM/°C)
MCSL0508	0.5W	$5 \leq R \leq 30$	-55~+170°C	±75
MCSL0612	1.0W	$5 \leq R \leq 30$	-55~+170°C	±75
MCSL0612	1.0W	$2 \leq R \leq 4$	-55~+170°C	±100

Performances

Environmental Performance

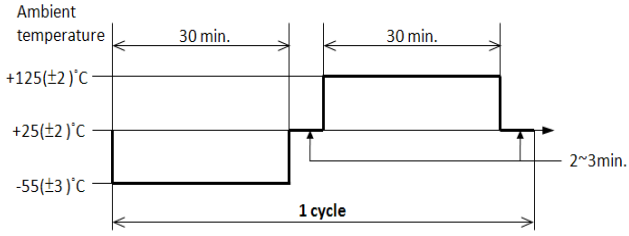
No.	Item	Test Condition	Specification
1	Short Time Overload	5 times rated power for 5 sec , (JIS-C5202-5.5)	ΔR: ±(1%+0.0005Ω)
2	Temperature Coefficient of Resistance (T.C.R.)	+25°C /+125°C. (JIS-C5202-5.2) $TCR \text{ (ppm/°C)} = \frac{\Delta R}{R \times \Delta t} \times 10^6$	Refer to Electrical Specification
3	Damp Heat with Load	The specimens shall be placed in a chamber and subjected to a relative humidity of 90~95% percent and a temperature of 40° ±2°C for the period of 1000 hrs. (MIL-STD-202, Method 103)	ΔR: ±(1%+0.0005Ω)
4	High Temperature Exposure	The ship (mounted on board) is exposed in the heat chamber 125±3°C for 1000 hrs. (JIS-C5202-7.2)	ΔR: ±(1%+0.0005Ω)
5	Load Life	Apply rated power at 70±2°C for 1000 hours with 1.5 hours ON and 0.5 hour OFF. (JIS-C5202-7.10)	ΔR: ±(1%+0.0005Ω)
6	Rapid change of temperature	The chip (mounted on board) is exposed, -55±3°C (30min.)/+125±2°C (30min.) for 5 cycles. The following conditions as the following figure. (JIS-C5202-7.4) 	ΔR: ±(1%+0.0005Ω)

Function Performance

No.	Item	Test Condition	Specification
1	Bending Strength	Mount the chip to test substrate. Apply pressure in direction of arrow unit band width reaches 2mm(+0.2/-0mm) illustrated in the figure below and hold for 10±1 sec. (JIS-C5202-6.1) <div style="text-align: right; margin-top: 10px;">Unit: mm</div>	$\Delta R: \pm(1\%+0.0005\Omega)$
2	Solvent Resistance	The chip is completed immersion of the specimens in the isopropyl alcohol for 3 +5, -0) min., 25°C ±5°C. ((MIL-STD-202, Method 215)	Verify marking permanency. (Nor required for laser etched parts or parts with no marking)
3	Resistance to solder Heat	The specimen chip shall be immersed into the flux specified in the solder bath 260±5°C for 10±1 sec. (MIL-STD-202, Method 210)	$\Delta R: \pm(1\%+0.0005\Omega)$
4	Solderability	The specimen chip shall be immersed into the flux specified in the solder bath 235±5°C for 2±0.5 sec. It shall be immersed to a point 10mm from its root. (Sn96.5/Ag3.0/Cu0.5) (JIS-C5 202-6.11) <div style="text-align: center; margin-top: 10px;"> <p style="margin-top: 5px;">$h = 10\text{ mm}$ $H = 10\text{ mm min.}$</p> </div>	Solder shall be covered 95% or more of the electrode area.

Remark:

- a. The surface temperature of component should below 100°C.

Derating Curve

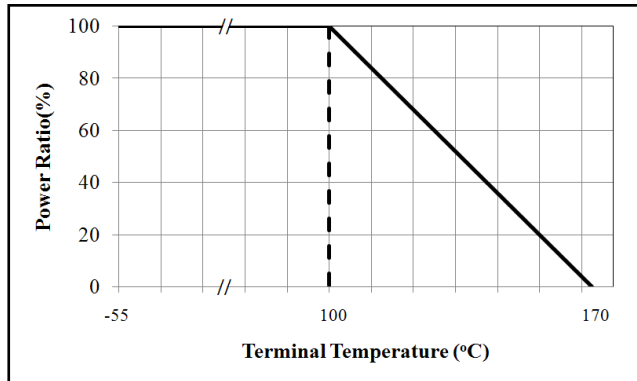

Tape Packaging Specifications

◆Paper Tape Specifications

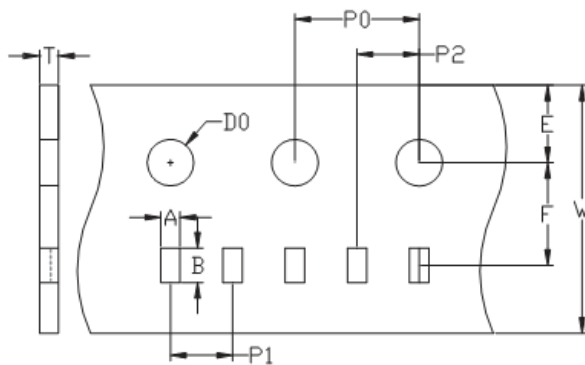

Unit:mm

Type	Carrier Dimensions									
	A	B	E	F	W	P0	P1	P2	D0	T
0508	1.6±0.1	2.4±0.1	1.75±0.1	3.5±0.05	8.0±0.2	4.0±0.1	4.0±0.1	2.0±0.05	1.55±0.05	0.97±0.1
0612	2.0±0.1	3.6±0.1	1.75±0.1	3.5±0.05	8.0±0.2	4.0±0.1	4.0±0.1	2.0±0.05	1.55±0.05	0.97±0.1

Packaging

Size EIA (EIAJ)	0508/0612
Standard Packing Quantity (pcs /reel)	5,000

Storage Conditions

Temperature : 5~35°C, Humidity : 40~75%

Recommended Solder Pad Layout

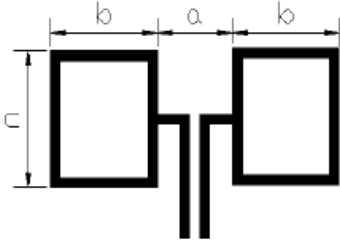

Type	Pad Layout Dimension (mm)		
	a	b	c
0508(ref)	0.5	1.30	2.60
0612(ref)	0.6	1.30	3.60

** Please contact factory if special layout.

Soldering Recommendations

- ◆ Peak reflow temperatures and durations :
 - IR Reflow Peak = 260°C max for 10 sec
 - Wave Solder = 260°C max for 10 sec
- ◆ Compatible with lead and lead-free solder reflow processes
- ◆ Recommended IR Reflow Profile :

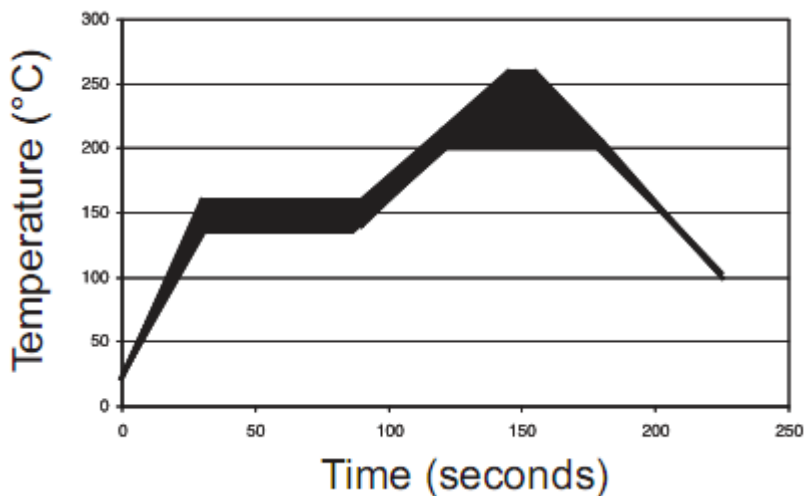

ECN

Engineering Change Notice : The customer will be informed with ECN if there is significant modification on the characteristics and materials described in Approval Sheet.

Disclaimer

ALL PRODUCT, PRODUCT SPECIFICATIONS AND DATA ARE SUBJECT TO CHANGE WITHOUT NOTICE TO IMPROVE RELIABILITY, FUNCTION OR DESIGN OR OTHERWISE.

Wellcomp Technology CO., LTD, its affiliates, agents, and employees, and all persons acting on its or their behalf (collectively, "Wellcomp"), disclaim any and all liability for any errors, inaccuracies or incompleteness contained in any datasheet or in any other disclosure relating to any product.

Wellcomp makes no warranty, representation or guarantee regarding the suitability of the products for any particular purpose or



WMCSL Series

Long Terminal Metal Strip Current Sensing Resistor

Document No: 20190903001
Issued Date: 2019/9/3
Version: A04

the continuing production of any product. To the maximum extent permitted by applicable law, Wellcomp disclaims (i) any and all liability arising out of the application or use of any product, (ii) any and all liability, including without limitation special, consequential or incidental damages, and (iii) any and all implied warranties, including warranties of fitness for particular purpose, non-infringement and merchantability.

Statements regarding the suitability of products for certain types of applications are based on Wellcomp's knowledge of typical requirements that are often placed on Wellcomp products in generic applications. Such statements are not binding statements about the suitability of products for a particular application. It is the customer's responsibility to validate that a particular product with the properties described in the product specification is suitable for use in a particular application.

Parameters provided in datasheets and / or specifications may vary in different applications and performance may vary over time. All operating parameters, including typical parameters, must be validated for each customer application by the customer's technical experts. Product specifications do not expand or otherwise modify Wellcomp's terms and conditions of purchase, including but not limited to the warranty expressed therein.

Except as expressly indicated in writing, Wellcomp products are not designed for use in medical, life-saving, or life-sustaining applications or for any other application in which the failure of the Wellcomp product could result in personal injury or death. Customers using or selling Wellcomp products not expressly indicated for use in such applications do so at their own risk. Please contact authorized Wellcomp personnel to obtain written terms and conditions regarding products designed for such applications.

No license, express or implied, by estoppel or otherwise, to any intellectual property rights is granted by this document or by any conduct of Wellcomp. Product names and markings noted herein may be trademarks of their respective owners.